

SECTION Y-Y

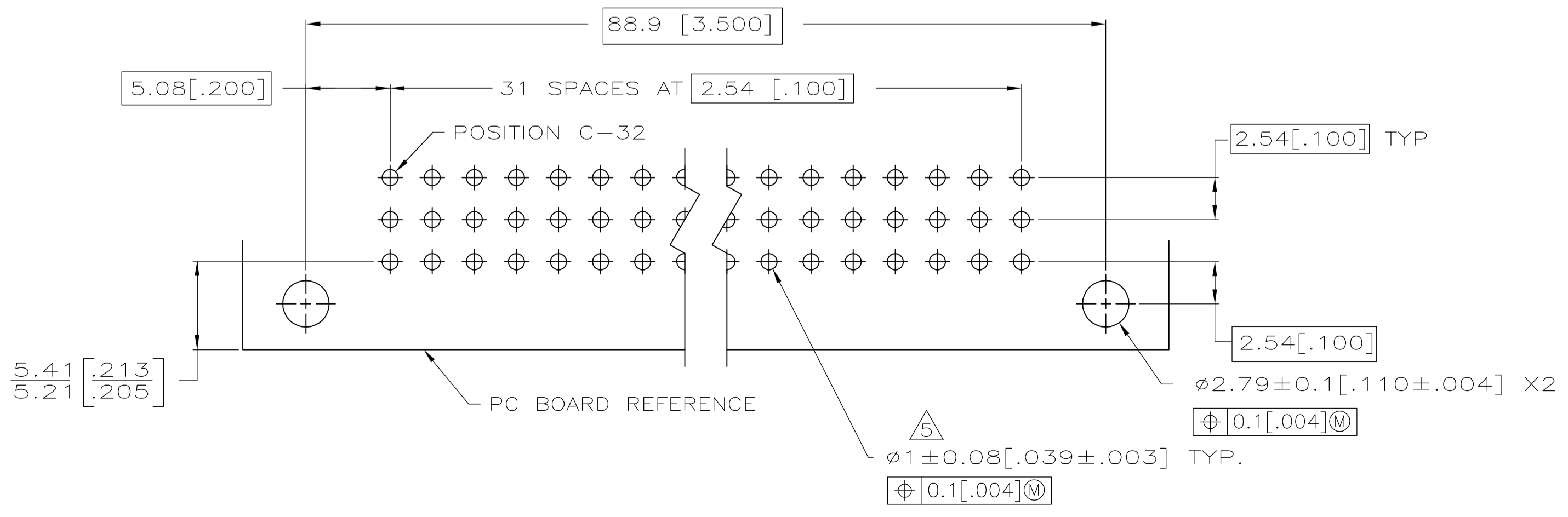
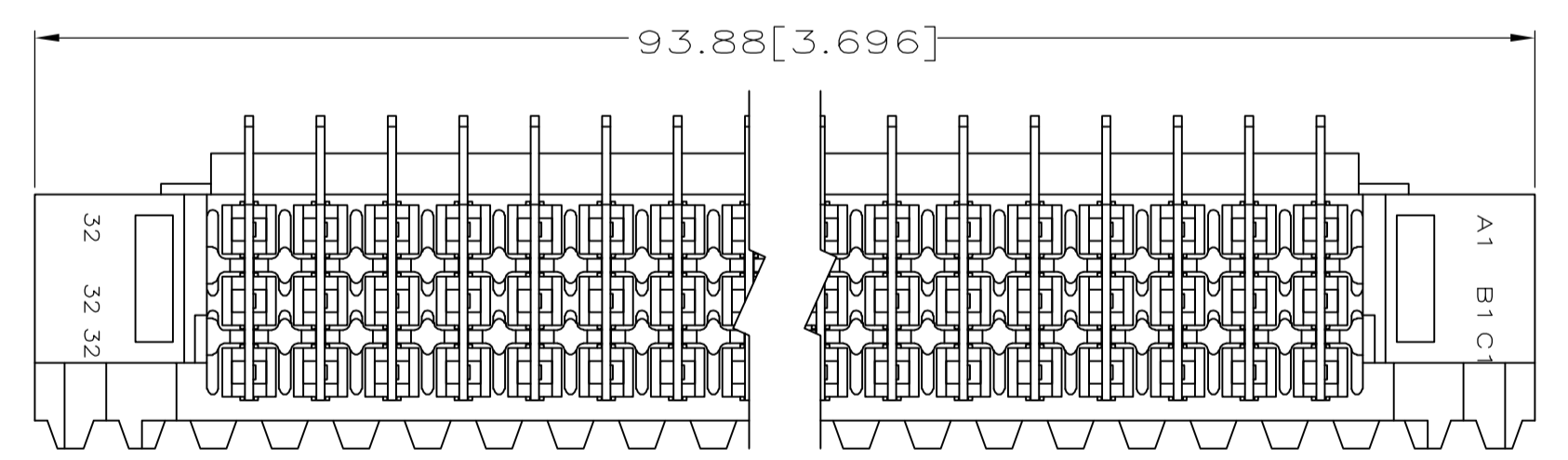

PC BOARD LAYOUT

1. DIMENSIONS IN BRACKETS ARE IN INCHES.
- 2 HOUSING MATERIAL: GLASS-FILLED POLYESTER. COLOR: GRAY.
- 3 CONTACT MATERIAL: PHOSPHOR BRONZE.
- 4 CONTACT FINISH: 0.00076[.000030] GOLD IN CONTACT AREA. 0.00127[.000050] NICKEL UNDERPLATE ALL OVER. TIN-LEAD ON POSTS.
- 5 RECOMMENDED HOLE SIZE FOR MANUAL APPLICATION OF CONNECTOR ONTO PC BOARD.
- 6 PART NUMBER, DATE CODE IDENTIFICATION, CSA LOGO HOT-STAMPED THIS APPROXIMATE AREA.
- 7 CONTACT POINT.
- 8 HOT-STAMPING ON THIS SIDE.
- 9 CONTACT FINISH: DIN 41612 CLASS 3 IN CONTACT AREA. TIN-LEAD ON POSTS.
- 10 CONTACT FINISH: 0.00127[.000050] GOLD IN CONTACT AREA. 0.00127[.000050] NICKEL UNDERPLATE ALL OVER. TIN-LEAD ON POSTS.
- 11 CONTACT FINISH: DIN 41612 CLASS 2 IN CONTACT AREA. TIN-LEAD ON POSTS.

OBSOLETE	9	1 THRU 32	X	X	X	96	650461-9
OBSOLETE	11	1 THRU 32	X	X	X	96	650461-6
	11	1 THRU 32	X	X	X	96	650461-5
	4	1 THRU 32	X	X	X	96	650461-4
OBSOLETE	10	1 THRU 32	X	X	X	96	650461-1

NOTES	POSITIONS LOADED	ROWS LOADED	NO. OF LOADED POSITION	ASSY PART NUMBER
THIS DRAWING IS A CONTROLLED DOCUMENT.				
DIMENSIONS: mm [INCHES]		TOLERANCES UNLESS OTHERWISE SPECIFIED:		APPROVED
⌀		0 PLC ± -		DRASHER
⌀		1 PLC ± -		DRASHER
⌀		2 PLC ± -		DRASHER
⌀		3 PLC ± 0.13[.005]		DRASHER
⌀		4 PLC ± -		DRASHER
⌀		ANGLES ± -		DRASHER
MATERIAL		FINISH		WEIGHT
2 3		4 9 10 11		A1 00779 C=650461
CUSTOMER DRAWING		SCALE 4:1		SHEET 1 OF 1 REV S